



ELECTRIC HOT FOOD TABLES WITH ENCLOSED BASE AND SLIDING DOORS



Item #:	_____	Qty #:	_____
Model #:	_____		
Project #:	_____		

For Use with Optional Spillage Pans

HF-5E-240-DR Shown

FEATURES:

- Stainless steel body, top and legs
- Stainless steel undershelf
- Fiberglass insulation between each compartment
- Units intended for dry use. For hot water bath, must use optional Spillage Pans # **SP-A** (Aluminum) or # **SP-S** (Stainless)
- Stainless steel 8" support shelf with removable 3/8" thick poly cutting board - Ships K.D.

MATERIAL:

- TOP:** 20 gauge #302 stainless steel with die stamped pan openings. (11.875" x 20.062")
- BODY:** 22 gauge #430 stainless steel
- LEGS:** 18 gauge stainless steel with fully adjustable stainless steel bullet foot
- UNDERSHELF:** 22 gauge #430 stainless steel
- LINERS:** 8" deep, 22 Gauge galvanized (standard) or #302 stainless steel upgrade (**Model # SU-32**)
- CUTTING BOARD:** White Thermoplastic
- CUTTING BOARD BRACKETS:** 16 gauge #302 stainless steel

ELECTRICAL:

- 120V units yield 500 Watts
- 208V/240V dual voltage units yield 750 Watts at 208V and 1000 Watts at 240V
- 6' electrical cord with plug
- Infinite control knobs
- Indicator lights



Model #	Length	Width*	# of Wells	Volts	Amps	Watts	NEMA Plug	Wt.	Cu. Ft.
HF-2E-120-DR	A = 31-13/16"	30-5/8"	2	120	8.33	1000	5-20P	127 lbs.	28
HF-3E-120-DR	B = 47-1/8"	30-5/8"	3	120	12.50	1500	5-20P	155 lbs.	41.32
HF-4E-120-DR	C = 62-7/16"	30-5/8"	4	120	16.67	2000	L5-30P	197 lbs.	54.55
HF-2E-240-DR	A = 31-13/16"	30-5/8"	2	208/240	7.21/8.33	1500/2000	6-20P	127 lbs.	28
HF-3E-240-DR	B = 47-1/8"	30-5/8"	3	208/240	10.82/12.50	2250/3000	6-20P	155 lbs.	41.32
HF-4E-240-DR	C = 62-7/16"	30-5/8"	4	208/240	14.42/16.67	3000/4000	L6-30P	197 lbs.	54.55
HF-5E-240-DR	D = 77-3/4"	30-5/8"	5	208/240	18.03/20.84	3750/5000	L6-30P	215 lbs.	66.94

***Width Includes 8" Cutting Board**

NOTE: Units are not designed to cook or heat frozen or refrigerated foods. Food placed in tables should already be hot, and the table will maintain the proper temperatures

NEMA PLUGS: Your plug will look like this...



NEMA 5-20P



NEMA 6-20P



NEMA L5-30P

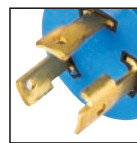

NEMA L6-30P

NOTE: For international applications, plug may need to be replaced (by others) in field.



Customer Service Available To Assist You 1-800-645-3166 8:30 am - 7:00 pm E.S.T.

For Orders & Customer Service:
Email: customer@advancetabco.com or Fax: 631-242-6900

For Smart Fabrication™ Quotes:
Email: smartfab@advancetabco.com or Fax: 631-586-2933

DIMENSIONS and SPECIFICATIONS

TOL ± .125"

ALL DIMENSIONS ARE TYPICAL

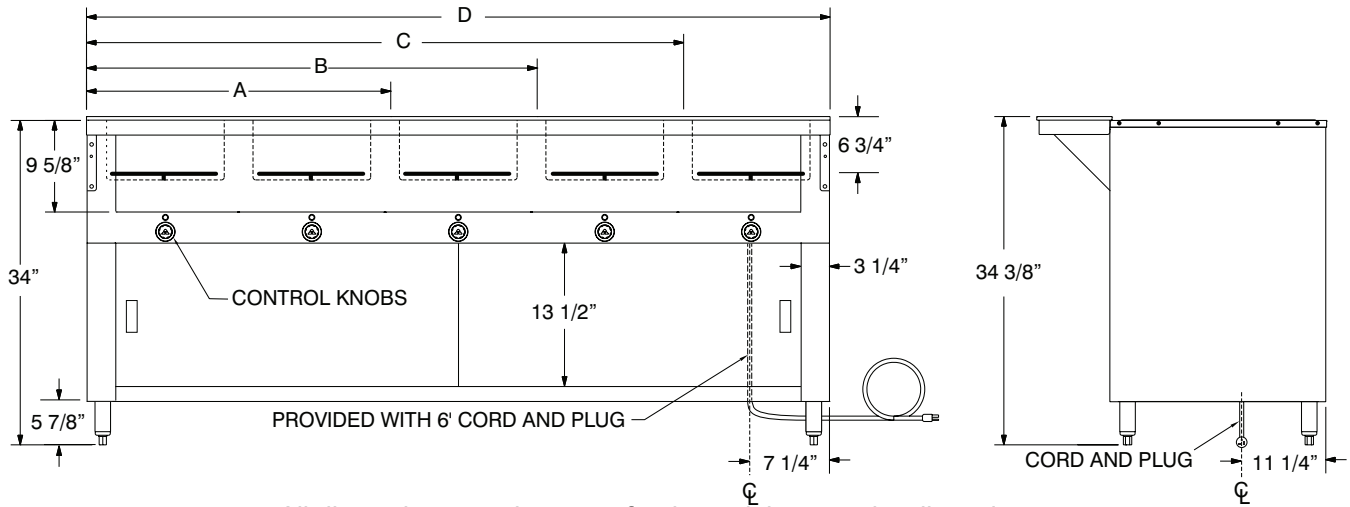
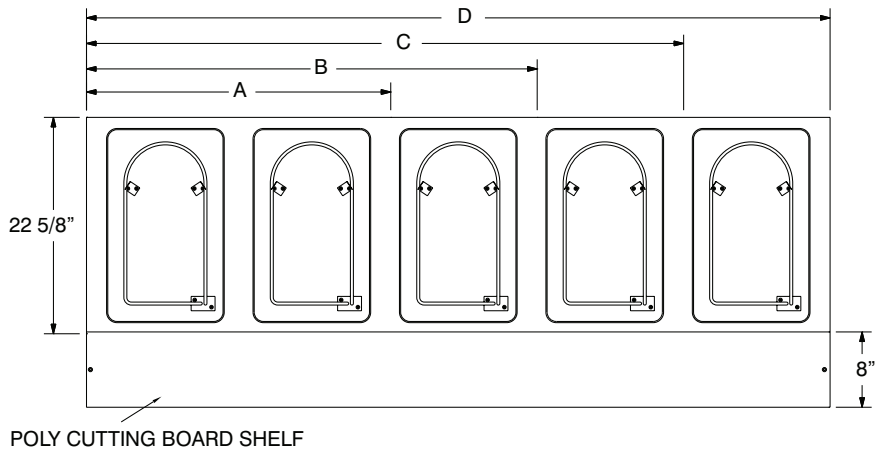

All dimensions are the same for the stainless steel wells option.

Food Table Accessories

Visit our website for additional Food Table Accessories



SP-A - Spillage Pan



SU-25 - Casters

- SU-32** Upgrade to a Stainless Steel Lining
(Excludes Sealed Hot Well Units)
- TA-255P** Add Casters to Enclosed Base Food Units
(Includes 4 -5" Swivel Casters, 2 w/ Brakes)
- SP-A** Aluminum Spillage Pan
- SP-S** Stainless Steel Spillage Pan
- SU-45A** 12" x 1" Adapter bar
- SU-45B** 20" x 3" Adapter bar
- SU-72** Upgrade to 240 volt units to 3-Phase Wiring
- TCB-OMIT** Remove Poly Cutting Board



Acrylic Food Shield has 10" Clearance from Deck

Double Sided Self-Serve Buffet Shelf with Built-In Food Shield

Model	Length	Approx Wt.	Cu. Ft.
TBS-2	31-13/16"	34 lbs.	2
TBS-3	47-1/8"	42 lbs.	3
TBS-4	62-7/16"	47 lbs.	4
TBS-5	77-3/4"	55 lbs.	4

